

KERB GULLY COVER
REF.286 - 250 KN

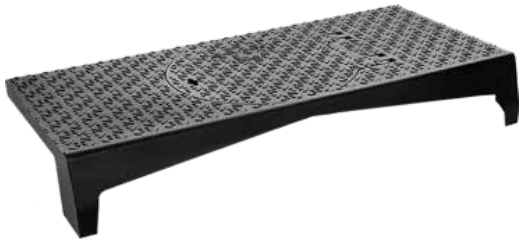

SPECIFICATIONS:

Loading: **250 kN**

MATERIAL & COATING:

Cover & frame:
Spheroidal cast iron EN-GJS-500-7.
Water based black paint.

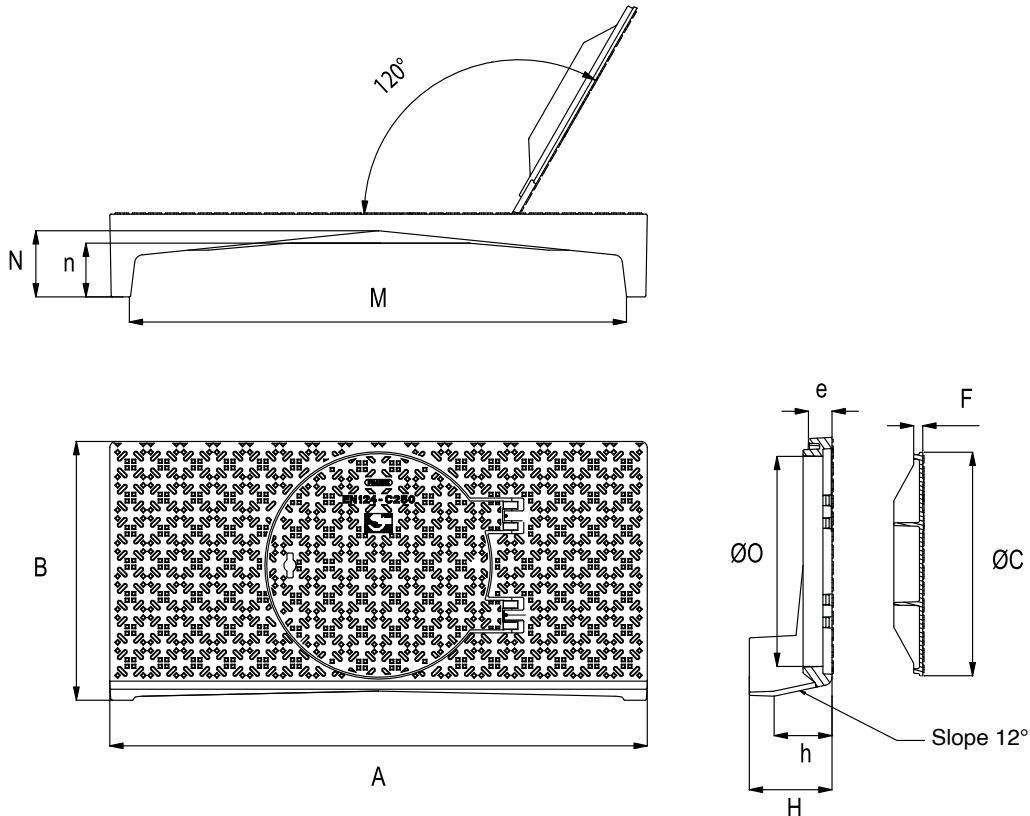

Ref.	A	B	Ø C	e	f	h	H	M	n	N	Ø O	Absorption surface	Weight		
													cover	total	
mm													dm2	Kg	
20203	1300	625	544	58	20	140	200	1200	130	160	508	15,3	22	125	