

1/2

**LOCKED HINGED & LIFT ASSISTED  
ACCESS COVER  
TITAN 1000 D400 CLASS**



**SPECIFICATIONS:**

Norm: **EN 124-2**  
Loading: **400 kN**  
Quality label: **Tüv** 

**MATERIAL & COATING:**

**Hatch cover:** Spheroidal cast iron  
EN-GJS-500-7. Water based black paint  
**Hatch frame:** Steel hot-dip galvanized  
**Hardware:** Stainless steel / cast Iron







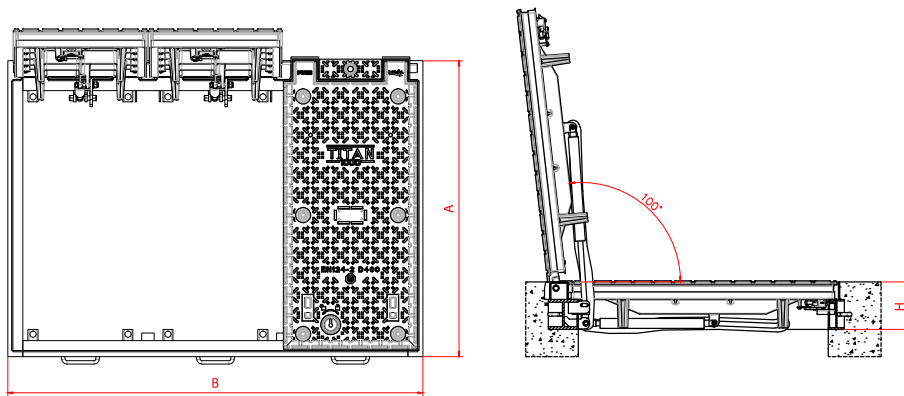

**OPTIONS:**

- Runoff watertightness / odortight
- Custom badging & logo
- Fall safety equipment
- Stainless steel gas strut assist lift
- Stainless steel mechanical strut (spring) assist lift
- Dense traffic flow

**REMARKS:**

Lift assisted  
Each cover equipped with an automatic burglar-proof lock «Pushed & Slammed»  
Special ergonomic key TITAN acting as a handle  
EPDM gasket: moulded monobloc - Hardness > 75 shore A, screwed mechanically underneath each cover



Reference	Description	Lay-out	Clear opening	Freeway	A*	B*	H*	Total weight
				mm				Kg
/	<b>TITAN-M1</b>		1000 x 460	890 x 460	1225	580	190	184
<b>32434</b>	<b>TITAN-M2</b>		1000 x 1000	885 x 1000	1225	1120	190	337
<b>32435</b>	<b>TITAN-M3</b>		1000 x 1540	885 x 1540	1225	1660	190	490
<b>32436</b>	<b>TITAN-M4</b>		1000 x 2080	885 x 2080	1225	2200	190	643
/	<b>TITAN-M5</b>		1000 x 2620	885 x 2620	1225	2740	190	796
/	<b>TITAN-M6</b>		1000 x 3160	885 x 3160	1360	3280	190	966
/	<b>TITAN-M7</b>		1000 x 3700	885 x 3700	1360	3820	190	1121
/	<b>TITAN-M8</b>		1000 x 4240	885 x 4240	1360	4360	190	1284
Weight / Lid (Kg)								105

\*External frame measuress. Other dimensions : on request

All dimensions, weights and norms are given for information only. SOVAL reserves the right to modify the specifications of products given in the present document.

2/2

**LOCKED HINGED & LIFT ASSISTED  
ACCESS COVER  
TITAN 1000 D400 CLASS**



**BESPOKE**

Covers are coated with a black water-based paint. In option, we offer a topcoating colored polyester paint - RAL color on request.

On request, each cover can be tailor-made by :

- a special badging & marking **embossed and moulded** in raw material
- set up of a **stainless steel plate**

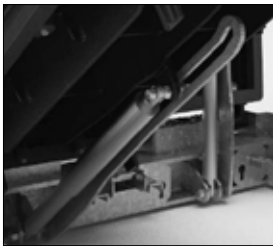

**LIFT ASSISTANCE**

Each cover is lift assisted in opening and closing for easy handling by a single person, by :

- **Standard Gas Strut**
- (option) **Stainless Steel Gas Strut**
- (option) **Stainless Steel Mechanical Spring**



**AUTOMATIC BURGLAR-PROOF LOCK**

«PUSHED & SLAMMED»

TITAN 1000 is equipped with lock device pushed & slammed on each cover:

- Burglar-proof, through hole
- Automatic closing
- Ergonomic key with two features : **locking/unlocking and handling in operation**



**(OPTION) RUNOFF WATERTIGHTNESS / ODORTIGHT**

Each cover is equipped with an **EPDM gasket** fastened by stainless steel screws.

Watertightness is obtained by the addition of crossbeams and **6 stainless steel compression bolts per cover**

**Related products**

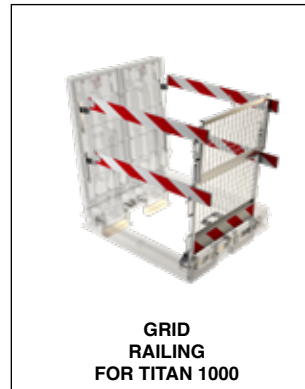

All dimensions, weights and norms are given for information only. SOVAL reserves the right to modify the specifications of products given in the present document.